

**IBANEZ EDGE & TOP LOK III
INSTRUCTION MANUAL**

Ibanez

Licensed Under Floyd Rose Patents

IBANEZ EDGE & TOP LOK III

The newest and finest tremolo unit from IBANEZ features knife-edge-like pivot surfaces for virtually friction-free operation. The bass side pivot and treble side pivot are of different shapes to eliminate side to side play common in other units of this type, for a more stable and accurate return to pitch. Several unique features set the IBANEZ EDGE apart from other tremolo systems. Fine tuners are located far to the rear of the unit, making right hand muting techniques possible without interference from the tuning knobs. The shape of the fine tuning knob is designed for maximum ease of operation. The tremolo arm itself snaps in and out quickly and will not become loose with heavy use. Steel sleeves hold the anchor bolts firmly in the body for solid sustain and stability.

Careful selection of materials and precision manufacturing techniques assure that each IBANEZ EDGE tremolo system is an exacting, professional quality unit. Through a casting technology known as the Lost Wax Method, IBANEZ is able to use a dense, harder formulation of metal that is normally possible to make the IBANEZ EDGE tremolo. The result is especially evident in the saddles and TOP LOK III; ringing harmonics and sustaining tone.

(Licensed Under Floyd Rose Patents)

ADJUSTMENT PARTS

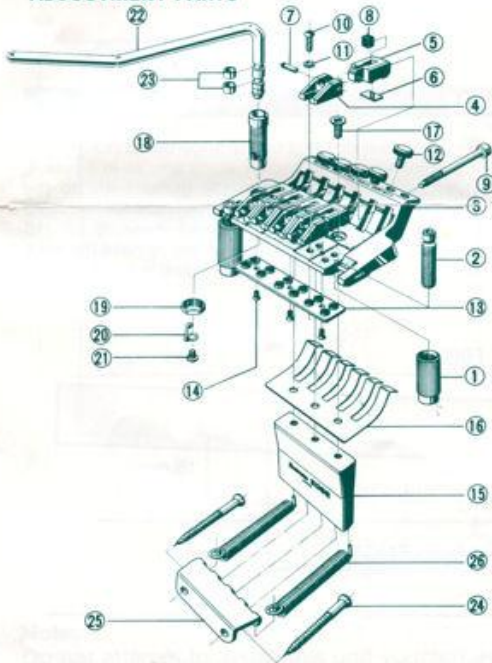

- ① Anchor
- ② Bridge height adjustment bolt
- ③ Base
- ④ Saddle
- ⑤ Main saddle
- ⑥ Plate
- ⑦ Pin
- ⑧ Holder block
- ⑨ String stopper bolt
- ⑩ Bolt for saddle
- ⑪ Washer
- ⑫ Fine tuning bolt
- ⑬ Saddle holder

- ⑭ Saddle holder lock screw
- ⑮ Block
- ⑯ Spring plate
- ⑰ Block lock screw
- ⑱ Arm holder
- ⑲ Arm holder lock nut
- ⑳ Spring for arm holder
- ㉑ Spring lock screw
- ㉒ Arm
- ㉓ Torque bush
- ㉔ Spring tension adjustment screw
- ㉕ Spring hook

ADJUSTMENT OF TOP LOK III

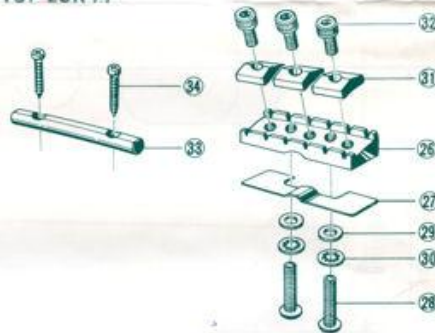

- ㉖ Locking nut
- ㉗ Spacer
- ㉘ Locking nut lock bolt
- ㉙ Washer
- ㉚ Toothed lock washer
- ㉛ Pressure pad
- ㉜ Pressure pad bolt
- ㉝ Retainer bar
- ㉞ Retainer bar screw

STRING CHANGE PROCEDURE

Fig. 1



Fig. 2

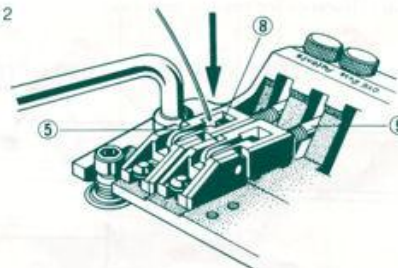
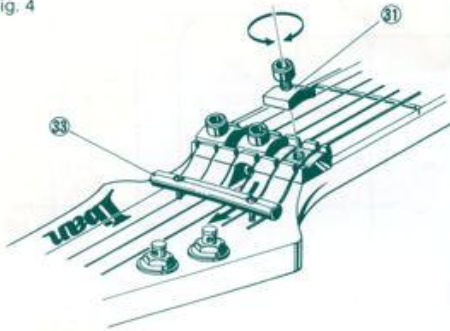

Fig. 3



IBANEZ EDGE & TOP LOK III

Fig. 4



1. Unscrew and remove nut clamp pressure pad ③①.
2. Unwind string using machine head.
3. Loosen string stopper bolt ⑨ and remove string.
4. Cut the ball end off of new string above winding as in Fig. 1.
5. Insert string between locking block ⑧ and string saddle ⑤ as in Fig. 2, and tighten saddle clamp securely.
6. Put other end of string under retainer bar ③③ and wind onto machine head as in Fig. 3.
7. Set fine tuning screw at half-way position to allow for raising and lowering of pitch.
8. Tune the string to pitch using machine head.
9. After tuning all strings to pitch, replace nut clamp pressure pad and tighten as Fig. 4.

* It is suggested that one string at a time be changed as opposed to removing all strings at once. This will help maintain bridge angle alignment and make returning the guitar easier.

INTONATION ADJUSTMENT

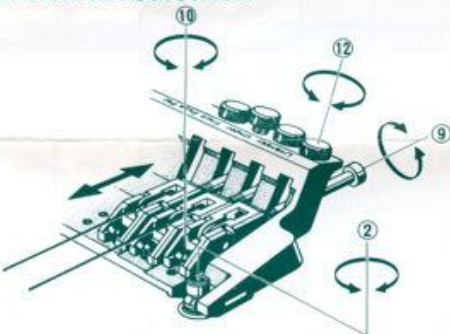

1. Check 12th fret harmonic against fretted note at 12th fret.
2. Unclamp locking nut pressure pad and loosen the string to be adjusted.
3. Loosen bolt for saddle ⑩.
4. Push the saddle forward (towards headstock) by hand if the 12th fret harmonic is higher than the fretted note. Pull saddle back (towards fine tuners) if harmonic is lower than the fretted note.
5. Retune the guitar and check 12th fret harmonic against the fretted note.
6. If harmonic and fretted note are not the same, repeat steps 2, 3, 4 and 5.

LEVEL AND HEIGHT ADJUSTMENT

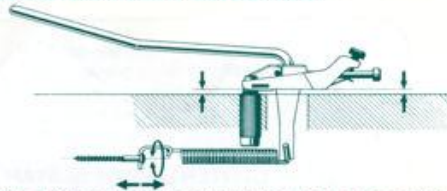

The bridge should be adjusted so that it sits parallel to the surface of the guitar. This is accomplished by tightening or loosening the tremolo tension springs by means of the two large phillips head screws ②④ located behind the rectangular plastic plate on the back of the guitar. Once the adjustment is made, it should only need to be changed when changing string gauge or brand of strings.

The overall bridge height can be adjusted by raising or lowering the height adjusting bolt ② located in the bridge anchors. To avoid excessive wear of the knife-edge pivots on the bridge, it is suggested that the strings be loosened before attempting to adjust bridge height.

TREMOLO ARM AND HOLDER SNAP IN/SNAP OUT TREMOLO ARM

Put the arm into the arm holder at a 90° angle to the holder. Push the arm in at position C.

Note: Attempting to push the arm in at position A or B may result in damage to the arm due to uneven pressure.

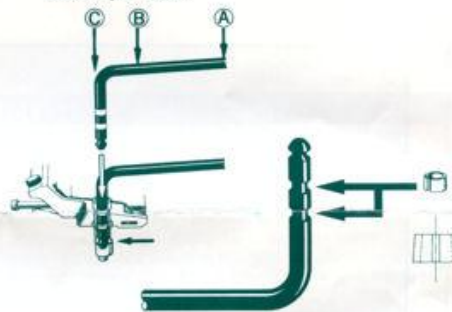

MAINTAINING DESIRE TORQUE CHANGING

Changing the torque bushes will enable you to regain the desired torque. When changing the bushes, be sure to follow these instructions carefully:

1. Remove the old bush.
2. Make sure the right side of the new bush is facing up.
3. Insert the new bush.

Unless these instructions are followed, damage to the arm may result.

REMEMBER: This is a precision engineered instrument. Any error in setup may result in unsatisfactory performance.

STUD LOCK

STUD LOCK AND BRIDGE HEIGHT ADJUSTMENT

To improve tuning stability of our Edge tremolo, a small screw inside the height adjustment bolt locks it into metal anchor sunken into the body.

Loosen this screw using the 1.5 mm wrench (See figure 1) provided before attempting to raise or lower the action. (See figure 2)

If the height adjustment bolt feels hard to turn, check to see that the stud lock screw has been loosened enough. After adjusting the bridge height, retighten the stud lock screws.



FIG. 1

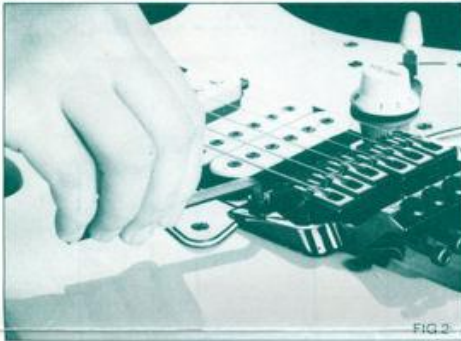
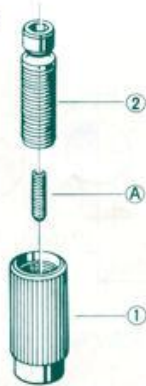

FIG. 2

- ② Bridge height adjustment bolt
- Ⓐ Stud lock screw
- ① Anchor



Ibanez

Fig. 1 TOP VIEW

RIGHT
HAND

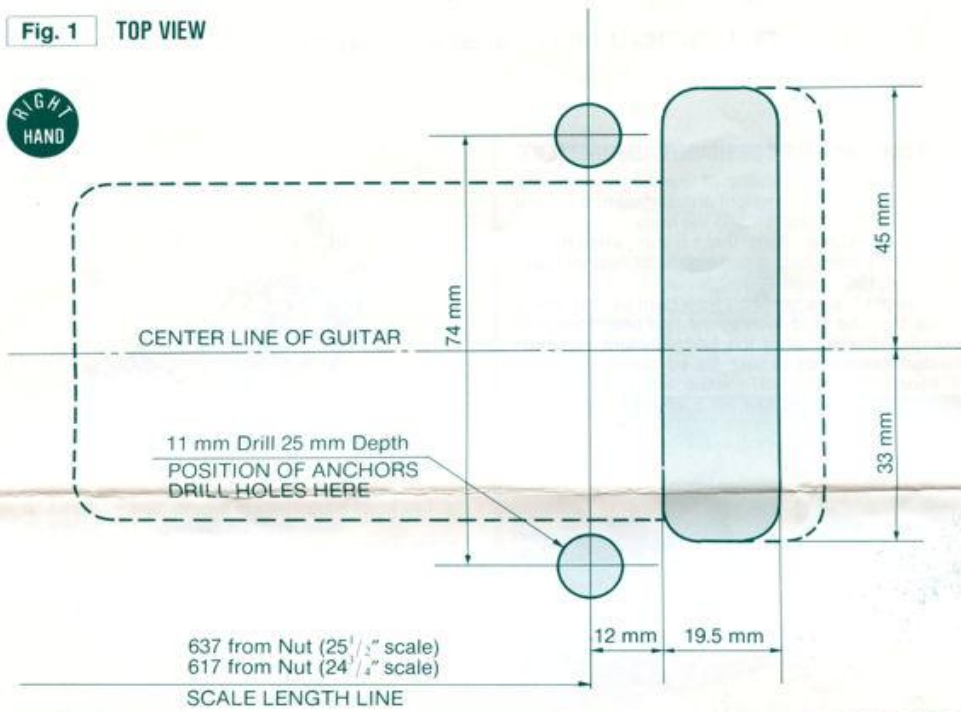

—— TOP VIEW
- - - - BACK VIEW

LEFT
HAND

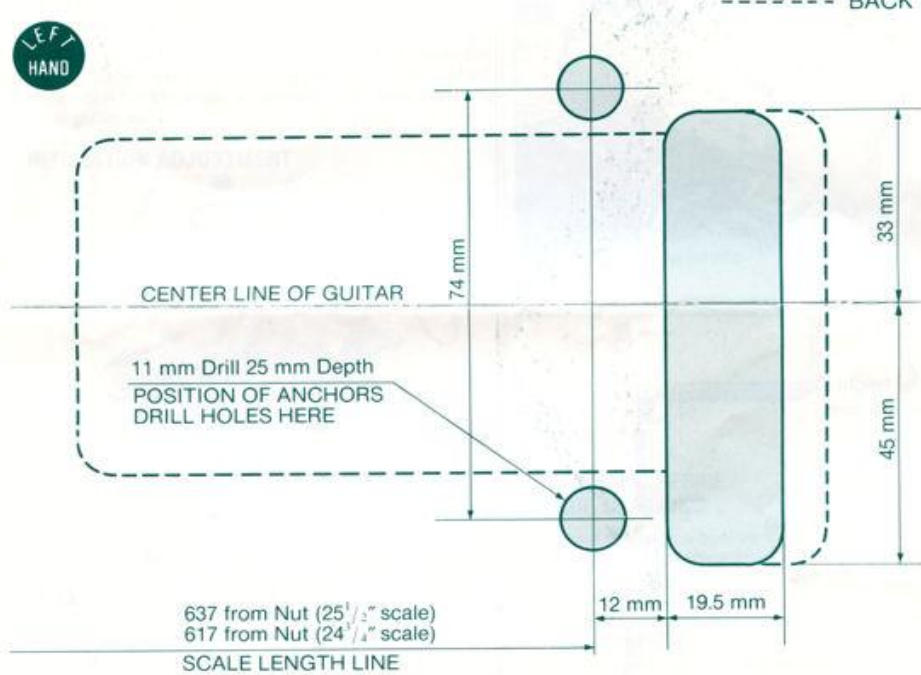

Note:

Do not use drawings as templates. Use only to design your own templates.

Fig. 2 BACK VIEW

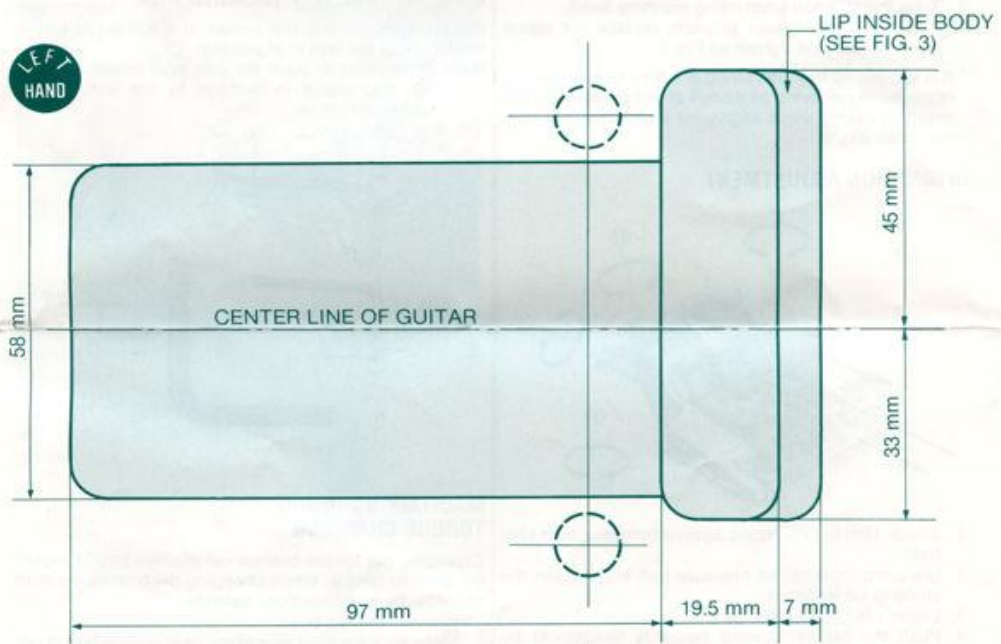
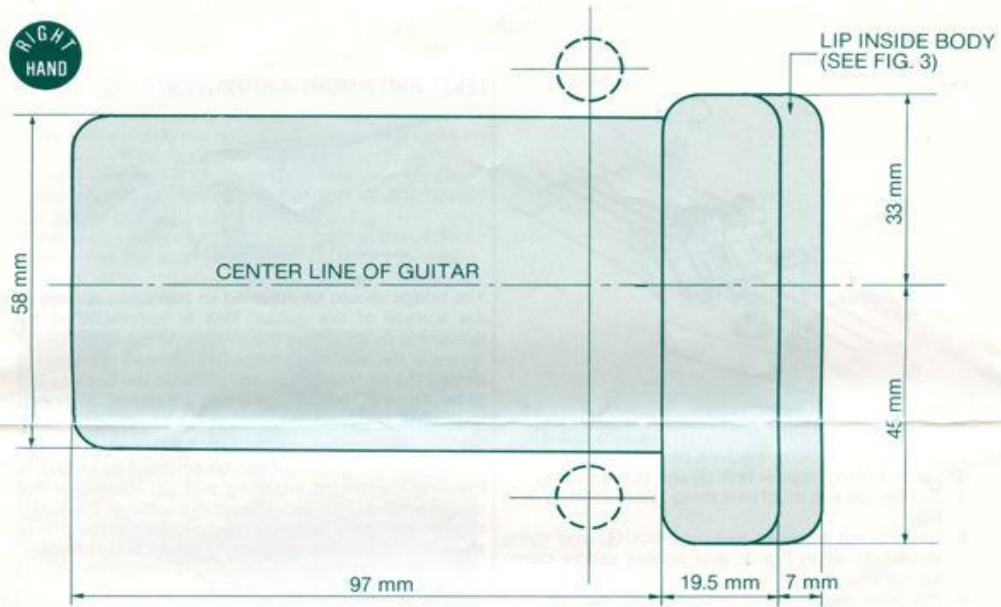

Note:
Do not attempt to install this unit yourself. Have the installation done by a qualified guitar repairperson.

BRIDGE UNIT

① Preparation:

All parts should be removed from the body of the guitar including the old bridge, pickups, controls, jack, etc. this gives you a clean uncluttered surface to work with.

② Measuring for position:

If the scale length of your guitar is:

$25\frac{1}{2}"$ (648 mm) — the center of the hole for the anchor should be located $25\frac{7}{16}"$ (637 mm) from the nut.

$24\frac{1}{4}"$ (628 mm) — the center of the hole for the anchor should be located $24\frac{1}{16}"$ (617 mm) from the nut. This measurement is used to place the bridge for accurate intonation.

③ Routing:

Supplied with the tremolo unit you will find drawings to be used in creating your own templates. DO NOT use these to guide a router. They are provided as a guide only.

④ Anchors:

After marking scale length, use the drawing for figure 1 to determine placement of anchors. After position has been marked, drill hole $1"$ (25 mm) deep using a $\frac{7}{16}"$ (11 mm) drill bit.

⑤ Bridge Block:

Using the drawing in figures 2 and 3 as a guide (or make template from the supplied template drawings), mark the areas on the guitar body to be routed. Carefully route the body to these dimensions.

Fig. 3 SIDE VIEW OF GUITAR

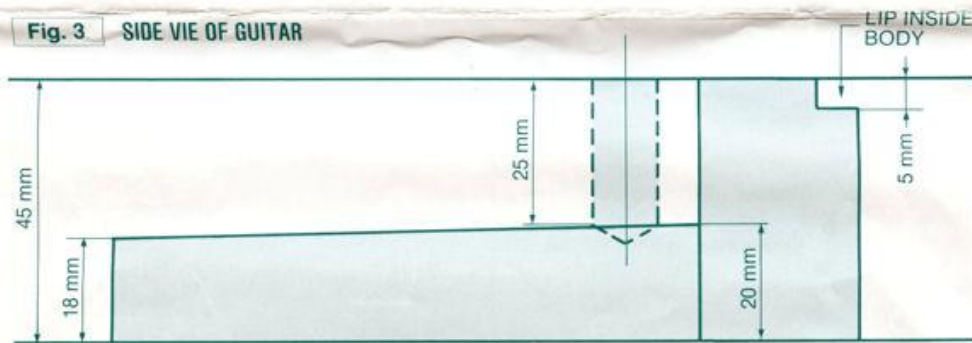

ASSEMBLY

① Install the bridge anchors by carefully tapping them in with a hammer until they seat in the bottom of the holes.

② Install the parts removed in step 1 — pickups, pickguard, etc. If the pickguard interferes with the operation of the tremolo, it must be modified to provide enough clearance for smooth operation.

③ Lay a straight edge on the fingerboard reaching to the point where the anchor studs are, as in figure 4. Measure the distance from the guitar body to the underside of the straight edge. For maximum tremolo performance, this distance should measure $\frac{1}{4}"$ (16 mm). If the neck angle is too shallow, remove the neck and add shims until this measurement is achieved.

Fig. 4 SETTING NECK ANGLE (USING A STRAIGHT EDGE)



TOP LOK III

① This locking nut is recommended for use with fingerboards having a radius of $14\frac{1}{32}$ " to $17\frac{1}{32}$ " (380 mm to 450 mm).

② **Cutting the Top Lok Mounting Surface** — Remove tuning gears from the headstock. Remove the old nut from the guitar. Using the drawing in figure 5 as a guide, cut the Top Lok mounting surface with a router.

③ **Drilling the mounting holes from the front of the neck** — Drill two holes all the way through the neck using a $\frac{1}{16}$ " (4.5 mm) drill bit, as shown in figure 5, for the locking bolts.

④ **Drilling the mounting holes from the back of the neck** — Drill two holes using a $\frac{1}{32}$ " (8.5 mm) drill bit to accommodate the locking bolt washers, as shown in figure 5.

⑤ **Installing the Top Lok unit** — Place the Top Lok unit on the mounting surface. Put a washer on each locking bolt and screw the bolt through the neck into the unit. Tighten securely.

⑥ **Retainer Bar** — Install the retainer bar behind the locking nut as shown in figure 5.

Screw the two bridge posts into the mounting anchors. Place the bridge in the guitar body and attach springs to bridge block. After the tuning gears have been re-installed, restrung the guitar and do intonation and setup.

Ibanez takes no responsibility for damage to the unit or guitar it is mounted on do to misuse or faulty installation. Always wear safety goggles when working with power tools

Fig. 5 TOP LOK ROUTE

